

Spectrum range of High Performance CCC equipment for mg to gram purifications

Dynamic Extractions specializes in offering separation and purification technology, which provides additional capability to chemists who want to purify products from *Discovery* stage through *Research & Development* to *Manufacture*.

The company develops separation technologies that provide chemists with additional tools for solving the challenges of their roles.

The **SPECTRUM** range of High Performance CCC (HPCCC) equipment is based on traditional liquid/liquid partitioning and extends the purification options available to chemists, in *Discovery* and *Development*, who are looking purify samples from mgs to 5-10 grams of material.

The equipment is easily connected and interfaced into existing LC equipment and provides options when existing solid phase technology cannot obtain the resolution required or when sample solubility is a problem.

The added advantage of the technique is that it is easily scales to preparative and kilo scale with no requirement to develop the separation method as it is directly transferable from analytical to kilo scale rapidly and easily.

The equipment is fully supported by the **Dynamic Extractions** support team that provides support through training, feasibility studies, method development and direct customer support. This ensures that all customers have peace of mind and confidence in the technique.

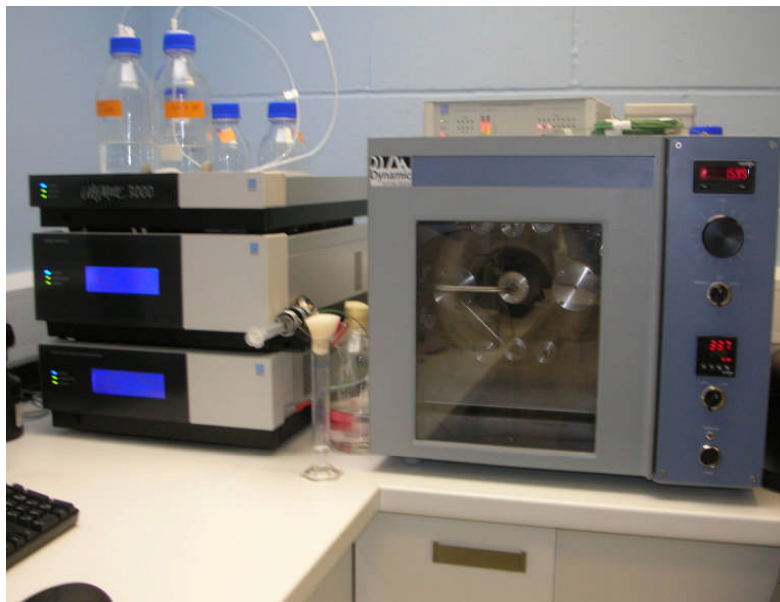

Benefits of Spectrum HPCCC to Chromatographers and Chemists

- Increased sample throughput
- Total sample recovery
- Improved sample solubility options
- Ease of reproducibility and scale-up
- Expanding operational capability
- Reduced sample preparation

Typical HPCCC applications in medicinal chemistry

- Where solubility of your sample is problematic to your existing RP purification techniques
- Where you want to purify target compounds from crude samples, which are early in their chemistry development and can not be handled by other techniques without significant sample preparation
- Product development where you do not want to redevelop your purification processes at each differing scale.

Technical Description

The **Dynamic Extractions** equipment is simple in concept and consists of a length of tubing wound in a coil on a drum which is centrifugally rotated in a planetary motion. Separations are achieved by partitioning the sample between two immiscible liquids: a stationary phase which is retained in the tubing and a mobile phase which is pumped through the tubing.

The operational process is extremely straightforward. The mixture is introduced in the mobile liquid and is separated into its component fractions by the time it emerges at the other end of the tubing. A separation of the mixture occurs, because along the tubing's length there are alternate mixing and settling zones created by the centrifugal forces generated. The order in which the fractions appear depends on how they distribute between the two liquids. The entire sample is recoverable, and highly pure fractions can be obtained since the sample undergoes up to 100,000 mixing and settling steps per hour. This allows the technology to be applied to the separation of substances, which are difficult to purify and/or may be unstable by other existing techniques.

Technical Specifications	Spectrum coils	
Column Volume (Nominal)	22 ml	136 ml
Sample load/injection	10-300 mg	1.0 -2.0 grams
Column (i.d)	0.8 mm	1.6 mm
Flow Rate (Max)	1 ml/min	10 ml/min

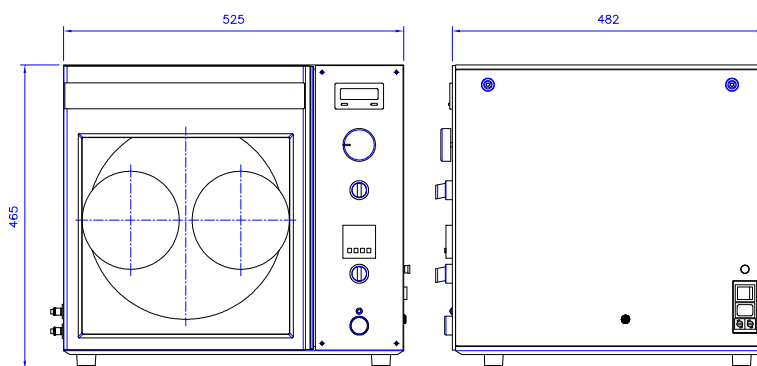

Standard Features

- **Performance** - 240g equipment allowing separations in minutes
- **Low pressure operation** – 60 -105psi (4 – 7bar)
- **Temperature control** – Ensures reproducible chemistry of separation
- **Easy to install** - Simply interfaced to existing LC equipment (pumps, detectors and fraction collectors etc)
- **Ease of use** – Simple inter change of coils allowing differing separation needs to be met quickly.
- **Safety features**
 - Column door interlock
 - Automatic shutdown on out of balance operation
 - Automatic shutdown on high temperature operation
- **Low solvent usage** – Typically 10% of that used in an equivalent solid phase separation

Dimensions	Spectrum	
Height	470 mm	18½"
Width	535 mm	21"
Depth	485 mm	19"
Weight	70 kg	154lb
Rotor Radius	85 mm	3.35"
Electrical Supply	230V/1ph/50-60Hz	
Power Rating	0.75 KVA	